

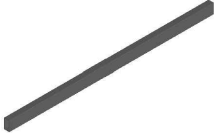



Componenti Components		Plastiche delle sedute (A) Polypropylene seat and backrest (A)		Trave x1 (B) Beam x1 (B)		Telaio (C) Frame (C)		Gamba per panca x2 (D) Leg for bench x2 (D)
SERIE VISUAL VISUAL SERIES		Piastra (E) Plate (E)						



VP525G RIB - VP526G RIB - VP527G RIB - VP528G RIB - VI525G RIB - VI526G RIB - VI527G RIB - VI528G RIB -
 VR525G RIB - VR526G RIB - VR527G RIB - VR528G RIB - VF525G RIB - VF526G RIB - VF527G RIB - VF528G RIB
 VP525N RIB - VP526N RIB - VP527N RIB - VP528N RIB - VI525N RIB - VI526N RIB - VI527N RIB - VI528N RIB -
 VR525N RIB - VR526N RIB - VR527N RIB - VR528N RIB - VF525N RIB - VF526N RIB - VF527N RIB - VF528N RIB

1) Uscire tutti gli elementi dalle scatole.

1) Extract all elements from the boxes



2) Uscire tutti gli elementi dalle scatole.

2) Extract all elements from the boxes



3) Uscire tutti gli elementi dalle scatole.

3) Extract all elements from the boxes

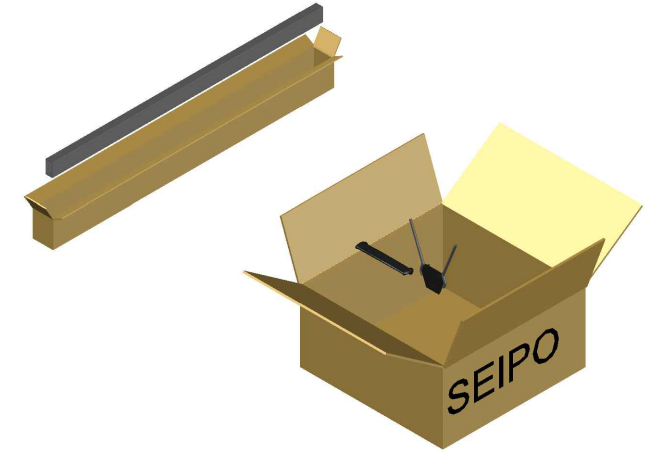

4) Comporre il telaio (C) per le panche ribaltabili.

4) Compose the frame (C) for the bucket benches



5) Inserire il telaio (C) e le gambe (D), nella trave (B) tramite una piastra (E).

5) Insert the frame (C) and legs (D) in the beam (B) by means of the plate (E)

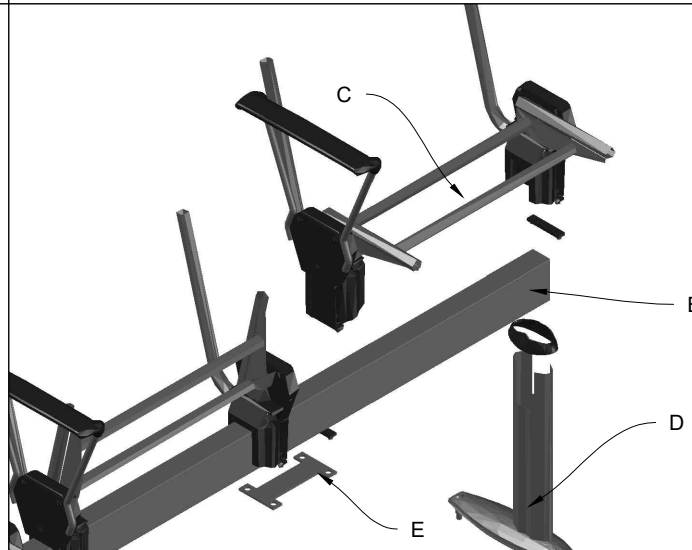

6) Inserire le plastiche delle sedute (A) nel telaio (C).

6) Insert the polypropylene seat and backrest (A) in the frame (C)

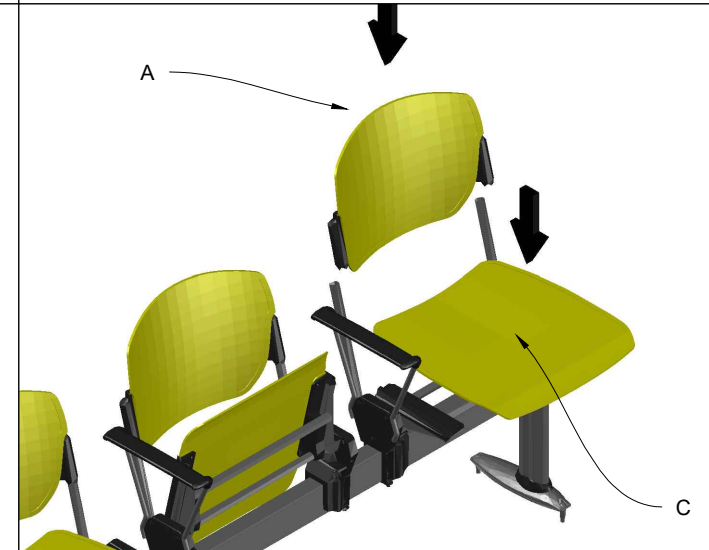

7) Per unire le due panche, agganciare le due travi (B) tramite una piastra (E) inserendola all'interno e serrarla con delle viti

7) Insert the union plate (E) inside the beam, tighten the screws to unite two beams (B)

8) Utilizzare una gamba (D) come punto di aggancio tra le due travi (B)

8) Use one leg (D) as a coupling point between the two beams (B)

9) Inserire le plastiche delle sedute (A) nel telaio (C).

9) Insert the polypropylene seat and backrest (A) in the frame (C)

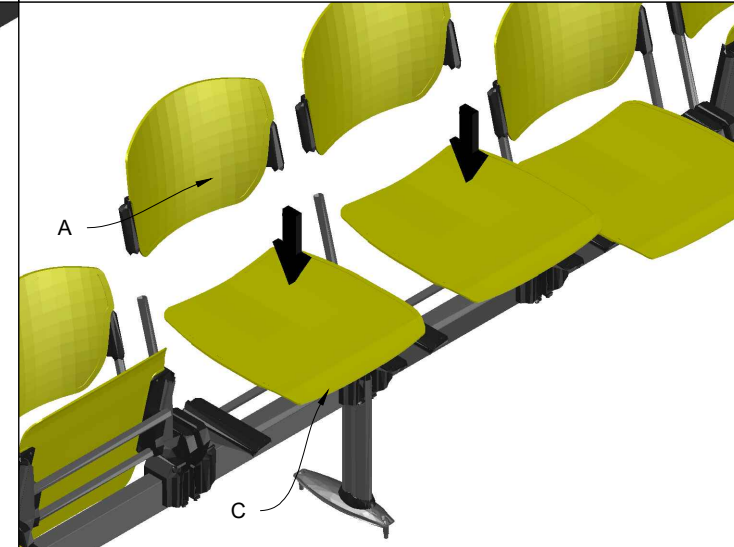
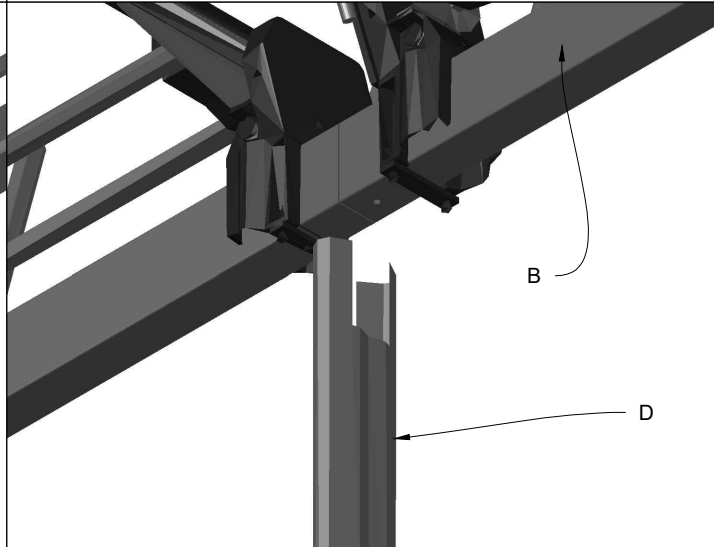
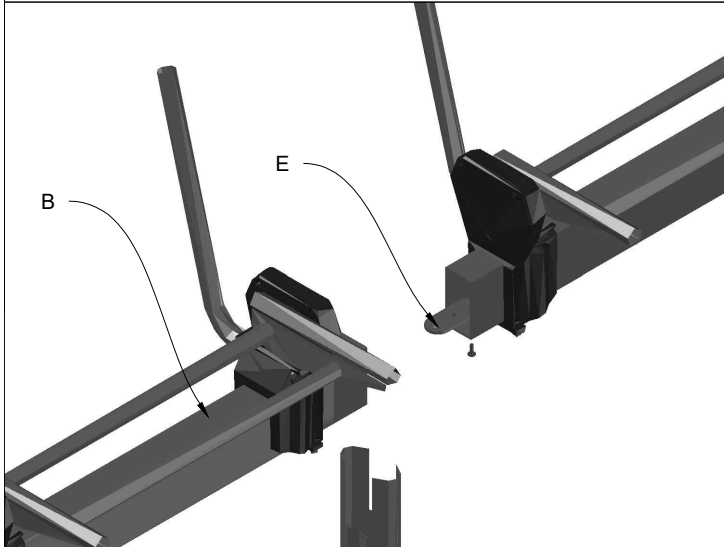

Per la regolazione del modulo ribaltabile: Caricare il meccanismo ruotando la chiave in avanti e innestare il telaio del sedile in posizione verticale

To adjust the folding module: Load the mechanism by turning the key forward and engage the seat frame in the upright position

PRETENSIONAMENTO:

PRETENSIONING:

- Sedile polipropilene ¼ di giro - Sedile tappezzato o metallico ½ di giro

- Polypropylene seat 1/4 turn - Upholstered or metal seat 1/2 turn

